

# Hardware for a Securely Mounting the Diversiboard

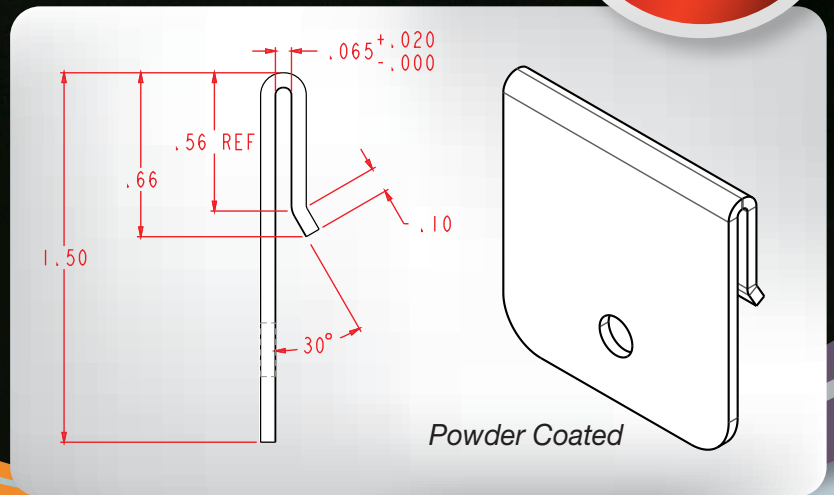

**Diversimount  
Wallmount Kit**



The part number **T-WMKIT Flush Wall Mount Kit** for **Diversiboard** facilitates flush mounting directly to any surface. Simplify your wall installation with factory provided hardware, designed specifically for the flagship **Diversiboard Projector Board** or **Diversiboard Marker Board**. The kit will work with any steel board that is fabricated with similar folded metal edges. Please see reverse diagram for clarification.

- + (1) Galvanized pre-drilled 4 hole cluster top horizontal board hanger
- + (3) 16 gauge powder-coated bottom mount steel board retainers
- + (1) Easy-To-Follow mounting instructions guide

*Powder Coating does not require a solvent to keep the binder and filler parts in a liquid suspension form. The coating is typically applied electrostatically and is used to create a hard finish that is tougher than conventional paint.*

**TRACK TECHNOLOGY  
SYSTEMS, INC.**

Corporate Address:  
10053 Whitney Way, Fishers, IN 46037



CALL TOLL FREE:  
**1-800-995-3177**

For more information, call our office, email  
[sales@diversitrack.com](mailto:sales@diversitrack.com) or visit [diversitrack.com](http://diversitrack.com).



# Diversiboard Flush Wall Mount Kit

46" long hanger - 16" and 24" O.C. hole provided

.70" REF

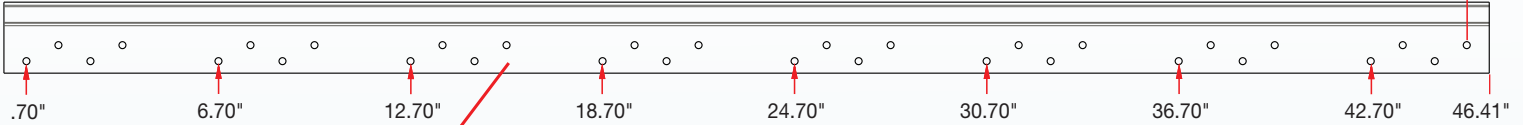

Place top rear lip of Diversiboard into the slot

Contents: For ALL Diversiboards EXCEPT for 48" x 96".

ONE top hanger strip and THREE powder coated bottom retainer clips.

For Diversiboard 48" x 96", TWO hanger strips & FOUR powder coated clips.

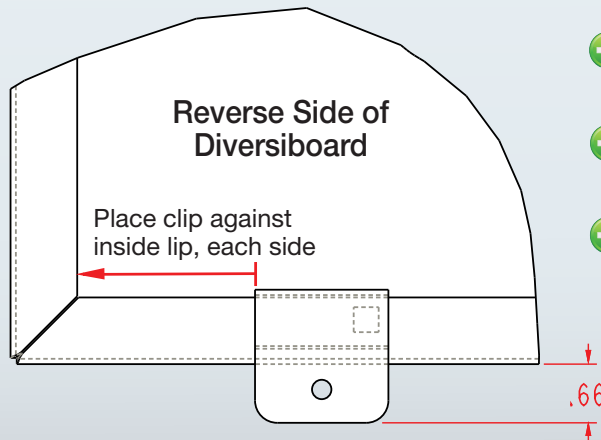
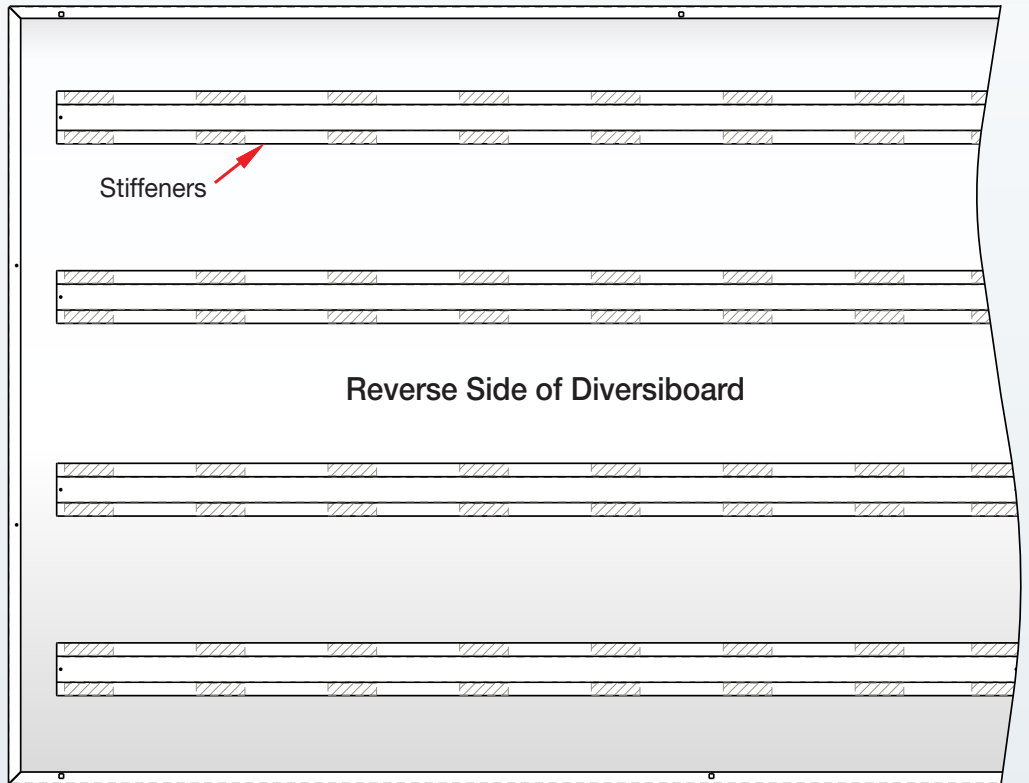
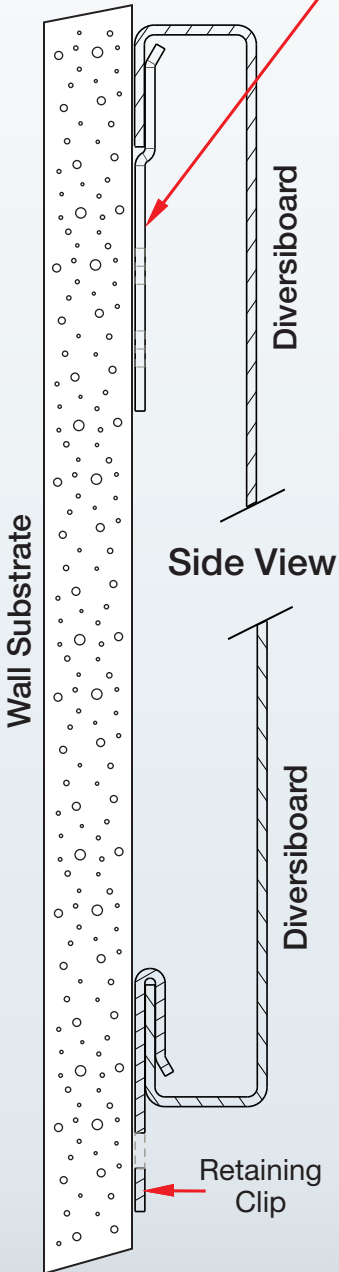

- + **DB-PB4872 48" x 72" Matte Steel Diversiboard Projector Board**
- + **DB-MB4872 48" x 72" Gloss Steel Diversiboard Marker Board**
- + **DB-MB4848 48" x 48" Gloss Steel Diversiboard Marker Board**

Revision 022616

**TRACK TECHNOLOGY SYSTEMS, INC.**

10053 Whitney Way, Fishers, IN 46037  
Email: sales@diversitrack.com



CALL TOLL FREE:  
**1-800-995-3177**

Visit our website at: [www.diversitrack.com](http://www.diversitrack.com)

Diversitrack is patented and an official trademark of Track Technology Systems, Inc.  
Diversimount is Patent Pending and an official trademark of Track Technology Systems, Inc.

